

NOSHOK Transducer and Transmitter Pressure Sensing Technologies

Diffused Silicon Semiconductor Strain Gauge Sensor (used in 100, 200, 612, 613, 615, 616, 621, 622, 623, 624, 625, 626, 627, 640 and 650 Series - ranges up to 0 psi to 300 psi)

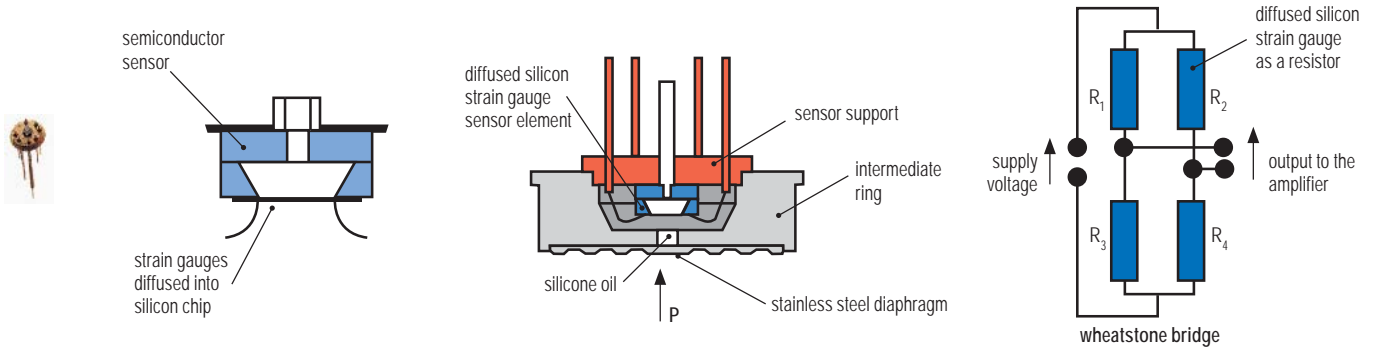

Sputtered Thin Film Strain Gauge Sensor (used in 100, 200, 612, 613, 615, 616, 621, 622, 623, 624, 625, 626, 627, 640, 650, 660, 800/810 Series - ranges 0 psi to 500 psi and higher)

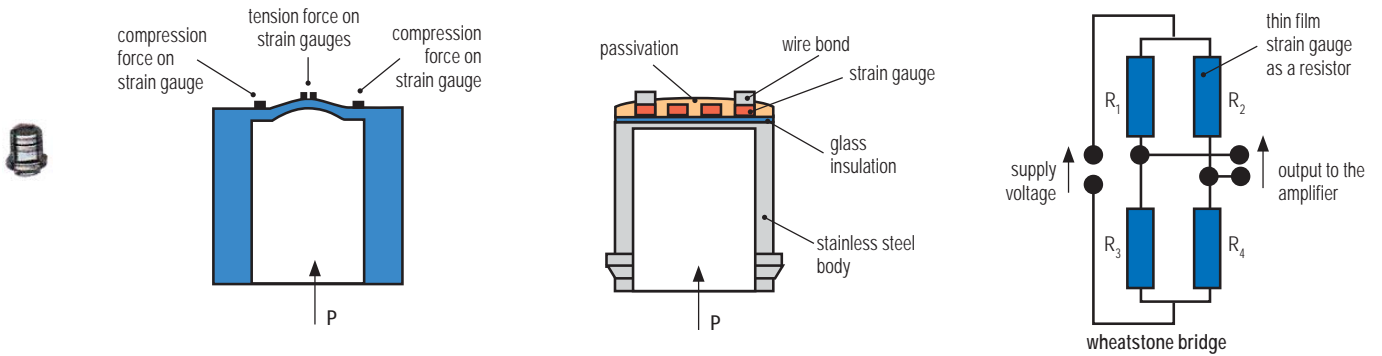

Ceramic Thick Film Strain Gauge Sensor (used in 800/810 and 1000 Series)

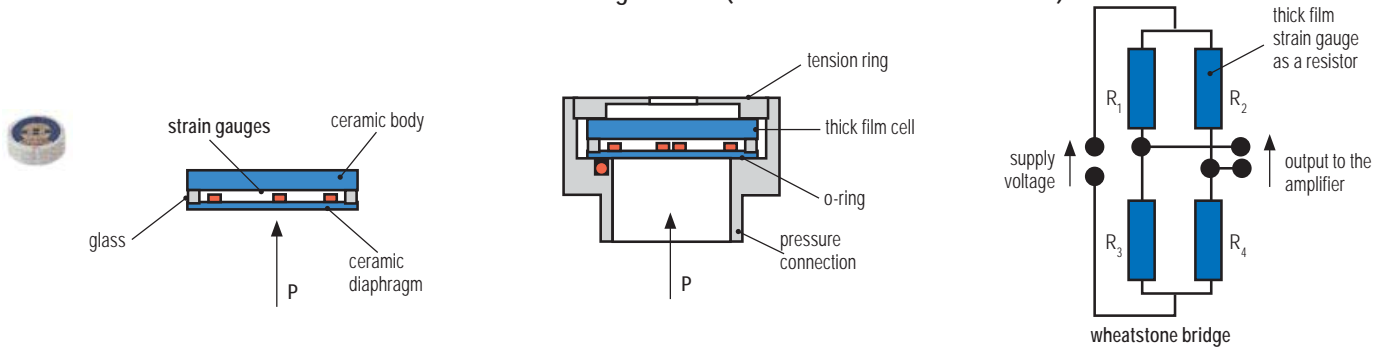

Hall Effect Sensor

